

(No Model.)

M. TANNENBAUM & M. GOTTDINER.
MARKING TOOL FOR LATHES.

No. 461,966.

Patented Oct. 27, 1891.

Fig. 1.

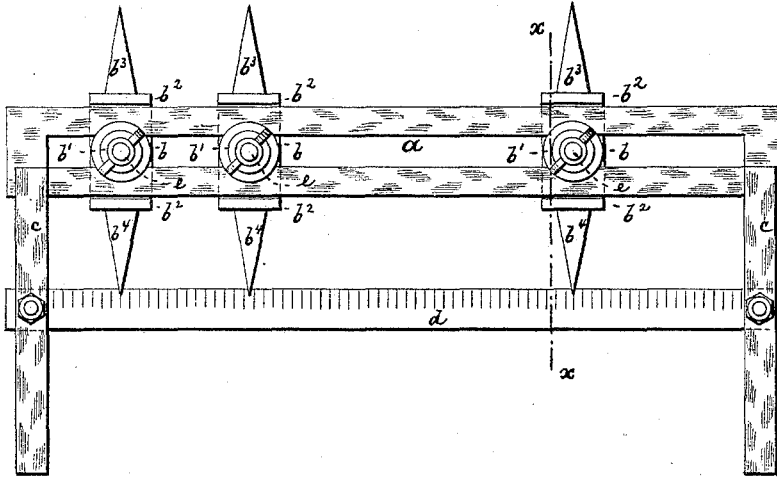
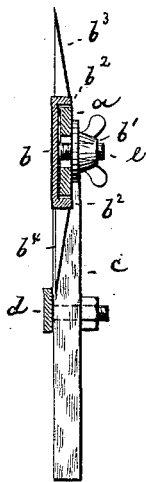

Fig. 2.



WITNESSES:

A. Schehl.
A. Goughmans

INVENTORS

M. Tannenbaum &
M. Gottdiner

UNITED STATES PATENT OFFICE.

MORRIS TANNENBAUM AND MICHAEL GOTTDINER, OF NEW YORK, N. Y.

MARKING-TOOL FOR LATHES.

SPECIFICATION forming part of Letters Patent No. 461,966, dated October 27, 1891.

Application filed April 21, 1891. Serial No. 389,744. (No model.)

To all whom it may concern:

Be it known that we, MORRIS TANNENBAUM and MICHAEL GOTTDINER, both of New York city, New York, have invented an Improved
5 Marking-Tool for Lathes, of which the following is a specification.

This invention relates to a tool adapted to be held against the work in a wood-turner's lathe, so as to mark the work at the points
10 where the cutters are to be applied. The tool being first set is ready to mark rapidly and in a uniform manner all the work that is to be turned out on the same pattern.

The invention consists in the various features of improvement more fully pointed out
15 in the claim.

In the accompanying drawings, Figure 1 is a face view of our improved marking-tool. Fig. 2 is a cross-section on line $x x$, Fig. 1.

20 The letter a represents a slotted bar, and b are a number of slides clamped to the bar by means of winged nuts b' , that engage screw-posts e , secured to the slides. The slides b are provided with shoulders b^2 at the front
25 and rear to insure a proper position and a rectilinear motion. Each slide is double-pointed, the forward point b^3 constituting a marking-tool, while the diametrically-opposite rear point b^4 constitutes an index-finger.
30 The screw post e projects upward from the

face of the slide midway between the points b^3 b^4 , as shown.

To the two ends of the bar a there are attached a pair of handles c , to which in turn there is secured a graduated rod or scale d ,
35 parallel to bar a and along which the fingers b^4 move.

In use the slides b are set to the desired pattern by means of the scale d , and then the tool is by the handles c held against the work
40 suspended in the lathe. A single revolution of the work will cause the markers b^3 to scratch circles at those points where the cutter is to be applied. In this way all the work to be
45 marked, after which the slides b are changed to a new pattern.

What we claim is—

The combination of bar a with slides b , having points b^3 b^4 diametrically opposite each
50 other, screw-post e , projecting upwardly from the face of the slide, a winged nut engaging the screw-post, and with a scale d and handle c , substantially as specified.

MORRIS TANNENBAUM.
MICHAEL GOTTDINER.

Witnesses:

A. JONGHMANS,
F. V. BRIESEN.